

E. C. ATKINS & F. FENTON.  
Crosscut-Saw Handle.

No. 218,914.

Patented Aug. 26, 1879.

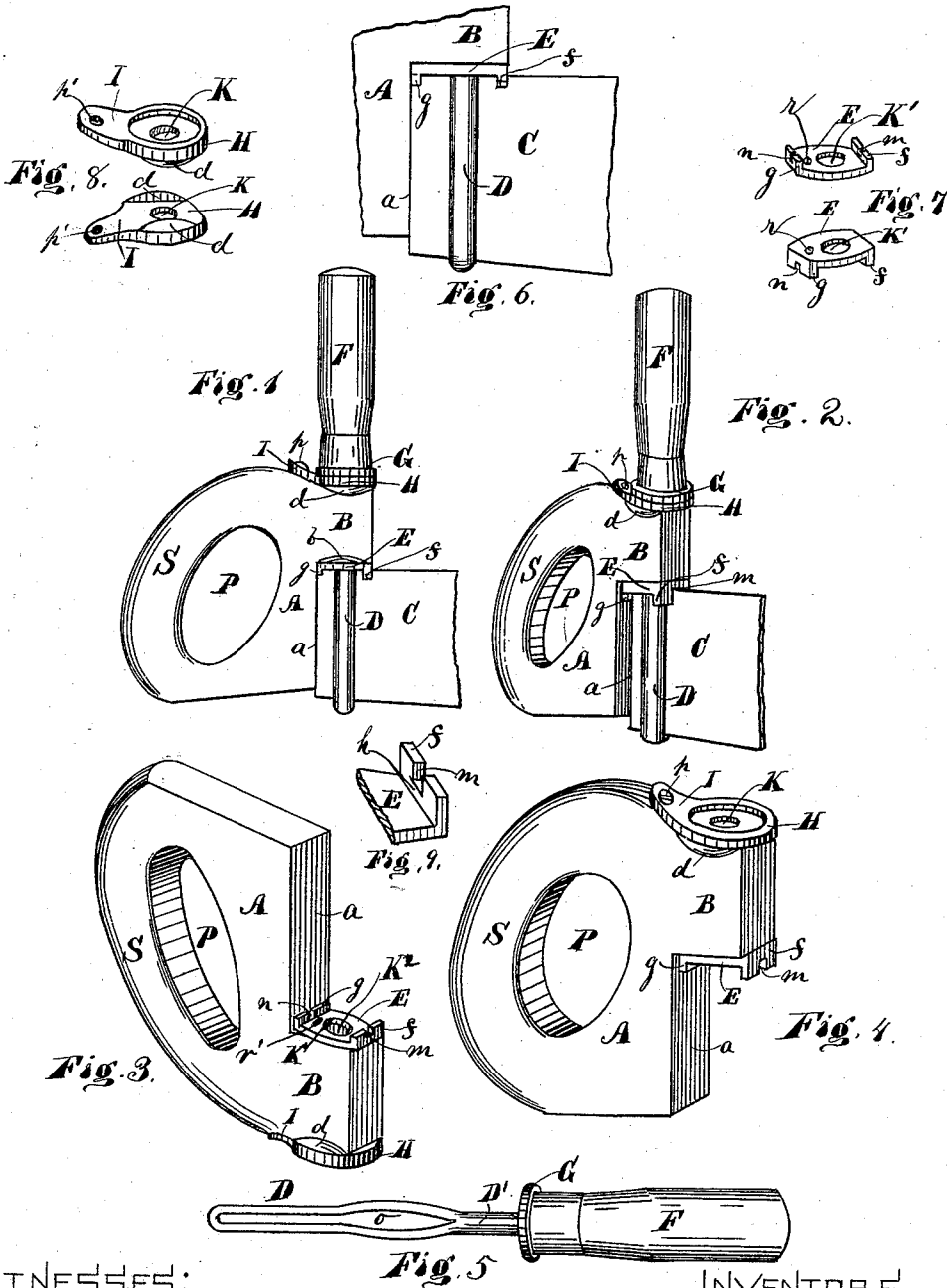

WITNESSES;  
George Remmett.  
L. F. Speer.

INVENTORS.  
Elias C. Atkins,  
Franklin Fenton,  
Per C. Wink, their Attorney.

# UNITED STATES PATENT OFFICE.

ELIAS C. ATKINS AND FRANKLIN FENTON, OF INDIANAPOLIS, INDIANA.

## IMPROVEMENT IN CROSSCUT-SAW HANDLES.

Specification forming part of Letters Patent No. **218,914**, dated August 26, 1879; application filed April 4, 1879.

*To all whom it may concern:*

Be it known that we, ELIAS C. ATKINS and FRANKLIN FENTON, both of Indianapolis, in the county of Marion and State of Indiana, have invented a new and useful Improvement in Crosscut-Saw Handles, of which the following is a description, reference being had to the accompanying drawings.

Our invention relates to certain improvements in that class of saw-handles which are intended to be used with one or both hands.

The object of our invention is to provide an improved device for a readier, securer, cheaper, and more durable mode of attaching removable handles to crosscut-saws than by the old methods.

Our invention is an improvement on the device patented to Elias C. Atkins, June 10, 1873, and numbered 139,756, and is adapted to be fastened to a saw-blade in which no holes for that purpose have been made, but with this distinct improvement, to wit: An additional or auxiliary wooden handle of peculiar construction, with clamping-blocks below and above, is introduced between the vertical handle and saw-blade, and firmly secured to the saw when the vertical handle is screwed up tightly, thus providing the saw with a rearward-projecting wooden handle in addition to the vertical one.

Our invention consists of the new construction and arrangement of parts, and in the new combination of old elements which are deemed essential in our newly-organized crosscut-saw handle, as will be hereinafter fully described, and set forth in the claims.

In the accompanying drawings, in which like letters of reference in the different figures indicate like parts, Figure 1 represents a side elevation of our improved saw-handle. Fig. 2 is a perspective view of the same. Fig. 3 is a perspective view of the auxiliary handle inverted, showing the arrangement of the saw-clamping block attached thereto. Fig. 4 also represents a perspective view of the auxiliary handle, showing the arrangement of the clamping block or washer on which the vertical handle is secured. Fig. 5 represents the vertical handle with split bolt in which the saw-blade is retained. Fig. 6 is an enlarged side view, same as in Fig. 1. Fig. 7 represents a per-

spective view of the top and bottom of the saw-clamping block. Fig. 8 represents a perspective view of the top and bottom of the upper washer or block on which the vertical handle is secured; and Fig. 9 represents the front of the saw-clamping block, showing the notch to receive the saw more fully.

Referring to the drawings, A represents a wooden handle having a hand-hole, P, and a round part, S, for the hand to grasp, and also provided with a projecting part, B, as shown. The projecting part B is provided with a vertical hole, K<sup>2</sup>, to receive the split bolt D' of the saw-clamp. To the lower side of the projecting part B of the handle A is secured the saw-clamping block E, which is of peculiar construction, to wit:

The plate E is provided with a hole, K<sup>1</sup>, to receive the bolt D, and has its ends *f* and *g* bent up or formed into flanges. The rear flange, *g*, has a small notch, *n*, formed therein, which extends down to the plate E to receive the upper edge of the end of the saw-blade C. The flange *f*, Fig. 9, is also provided with a notch, *m*, which extends only part way to the plate E, thus leaving a shoulder, *h*, and the saw-blade C is provided with a notch formed in its upper edge to fit into the notch *m*. The notch in the saw-blade locking over the part *h* prevents the saw from being pulled out endwise, while the sides of the notch *m* overlapping the saw-blade prevents it from moving sidewise. The block E may be perfectly flat on the upper face, as shown in Figs. 3, 4, 6, and 7, or it may be provided with side ribs, *b*, to fit on each side of the handle A B, as shown in Fig. 1, and is secured to said handle or projecting part B by the wood-screw *r*', passing through the hole *r*, as shown.

The upper block, H, forms a washer for the handle F to be secured to, and is provided with a hole, K, corresponding with the holes K<sup>1</sup> and K<sup>2</sup> in the block E and projecting part B of the handle for the bolt D to pass through.

The block H is provided with a projecting lug, I, having a screw-hole, *p*', to receive the screw *p*, which secures said block to the handle A, and at each side of the block H are ribs *d d*, to project over the sides of the handle and prevent lateral movement of the block, as shown.

The split bolt D D' is first inserted in the

holes K K<sup>1</sup> K<sup>2</sup> through the projection B and plates E H, and the handle F is then partially screwed on the bolt above the projection B. The saw-blade C is then inserted in the slot *o* of the bolt, with the notch at the upper part of the blade in the notch *m* of the plate E, the rear end of the upper edge of the saw resting in the notch *n*. The handle F is then screwed up tightly, thus binding the saw-blade and clamping the auxiliary handle A B between the saw-blade and handle F, the end of the saw-blade resting against the face *a* of the handle A B, as shown.

We are aware that saws with two handles at each end are old; also, that saw-blades have been clamped to handles by a split bolt and vertical handle, and therefore make no broad claim thereto.

What we claim is—

1. The auxiliary handle A, having a projecting end, B, combined with the vertical handle F, bolt D, flanged and notched plate E, the notches of which fit into the notches in the upper edge of the saw-blade C, and the saw-blade C, as described and set forth.

2. In combination with the auxiliary handle

A, having a projecting end, B, the clamp-block E, having flanges *f* and *g*, provided with notches *m n*, the block H, with perforated projecting end I and side flanges, *d d*, the vertical handle F, and split bolt D, as described, for the purpose specified.

3. The flanged block H, with the projecting end I, in combination with the saw-handle A B and split bolt F D.

4. The block E, with flanges *g f* and notches *m n*, said notch *m* being below the plane of the notch *n*, and not as deep as the notch *n*, in combination with the notched saw-blade, whereby the notch *m* receives the notch on the upper edge of the saw-blade, and makes an interlocking connection between said saw-blade and handle, all as shown.

In testimony whereof we have signed our names to this specification in the presence of two subscribing witnesses.

ELIAS C. ATKINS.  
FRANKLIN FENTON.

Witnesses:

H. KNIPPENBERG,  
GEO. E. HELM.